

FINE COAL - SCREENING

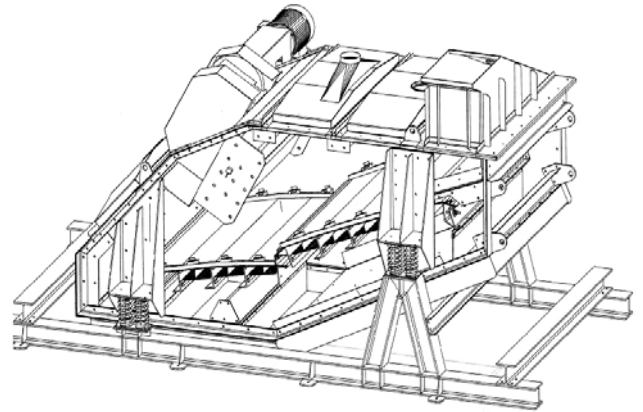

APPLICATION AND OPERATION:

To be used in power stations or other plants with coal firing for control screening of firing coal. In order to protect the firing plant against coarse and tramp material. The JÖST® screen SREN in dust tight execution with special screen deck is able to screen wet coal at low screen cut.

TECHNICAL DATA:

Type of machine:	SREN 2000 x 4000 - 6000
Width:	2.000 mm
Length:	4.000 mm
Declination:	banana type
Exciter:	JR 606, 18,5 kW
Product:	coal
Capacity:	300 t/h
Grain size:	0-50 (in grinding circuit)
Humidity:	up to 12 % in the fine product
Screen cut:	at 7 and 10 mm

YOUR BENEFIT:

- Capacity control via JÖST-CONTISEN®: Shut-down of the belt feeder when the screen is overloaded
- Co-vibrating inlet chute for proper distribution of the product on the screen deck
- Wear lining made of stainless steel against sticky material
- JÖST® frequency inverter for optimising the screen frequency
- Low built-in height due to co-vibrating material chutes
- Dust tight inspection openings for control and maintenance purposes
- Automatic screen deck cleaning by using a ball knocking device