

FURAN SAND RECLAMATION PLANTS

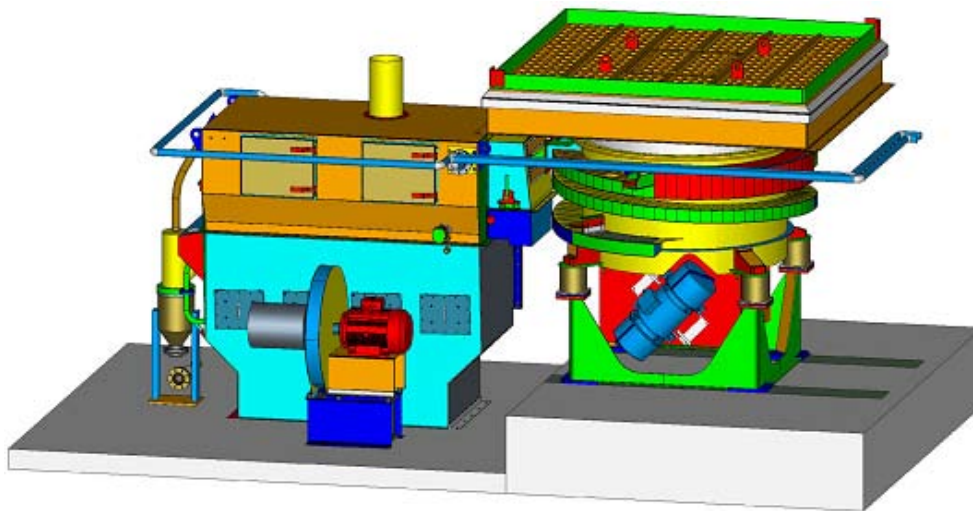

JÖST[®] Germany supplies complete turn-key sand reclamation plants for cold resin bonded sand. The available performance is from 1 t/h up to 20 t/h in single line applications. The available screen deck size range is up to 4500 x 4500 mm / 50 ton deck load in single deck applications.

JÖST[®] designs and manufactures the vibrating machines, the drive units and the sand coolers in the plant in Duermen / Germany; the whole process is in one hand:

- Design of the plant
- Detail engineering of the machines including FEM method for the investigation of the durability of the structures
- Design of the electronic control system - no interfaces!
- Manufacturing and test run in the factory
- Complete mounting and start-up with own staff
- After sales service and spare parts storage

TECHNICAL DATA AND FACTS:

The plant shown in the 3-D layout is a 10 t/h compact sand reclamation system with max. 10 ton deck load. The plant mainly includes:

- Shakeout / sand lump attrition unit with screen and spiral elevator
- Magnetic neodym drum to remove metallic particles
- Watercooled fluid bed cooler / sifter to remove the organic binder particles and to cool the sand down to 40° C.
- Pneumatic sand conveyor
- Electronic control system

YOUR BENEFIT:

- Compact dimensions
- Maintenance-low
- Very low construction height
- Low energy demand
- Good cost-genefit ratio / short mounting period